

THE METRICOPE

(Opportunity for Excellence)

Name:

Due:

Please view the picture and answer the questions below about laboratory safety.

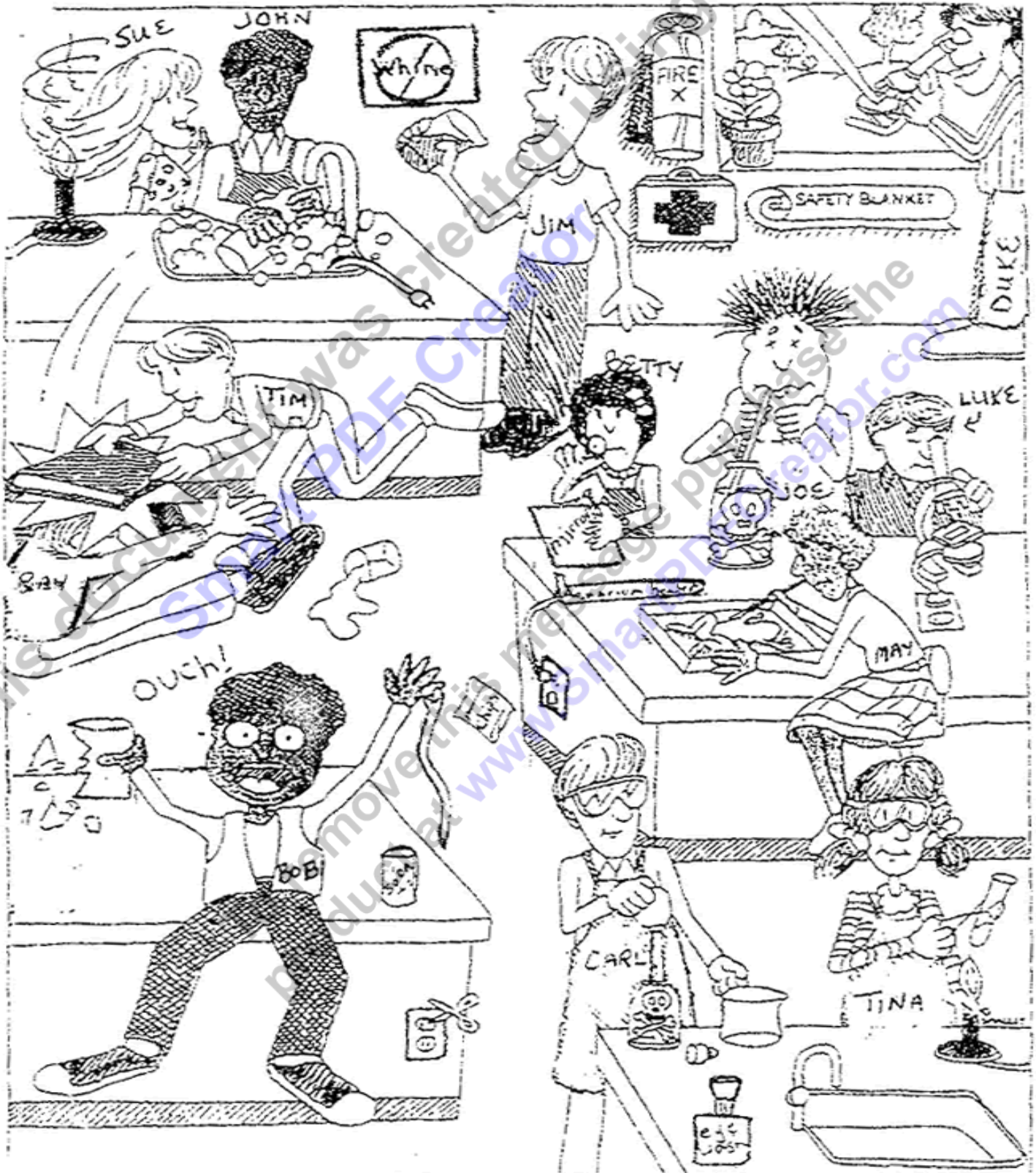

Write down the names of the students who are doing things right and wrong below.

Right ☺	Wrong! ☹
---------	----------

List 3 unsafe activities shown in the illustration and the person making them? Why is it unsafe?

--	--	--

List three items in the illustration that are there for the safety of the students in the lab.

--	--	--

What are three things shown in the lab that should not be there?

--	--	--

Describe two uses of magnification on the lines below. Write a couple of complete sentences that describe the specifics of the use.

1.) _____

2.) _____

Warning! 3 Part Question! 1) Record the name of each type of magnification device below. 2) Describe specifics about each of the picture below (what type of specimen does it magnify). 3) How does it work for the ones we learned?



Please label the parts of the compound light microscope below. Use the word bank below.

- | | | |
|-----------------|---------------------------|----------------------|
| 1) Base | 5) Diaphragm | 9) Stage |
| 2) Light Source | 6) Fine Adjustment knob | 10) Objective Lenses |
| 3) Body Tube | 7) Revolving nose piece | 11) Eyepiece |
| 4) Stage Clips | 8) Coarse Adjustment Knob | 12) Arm |

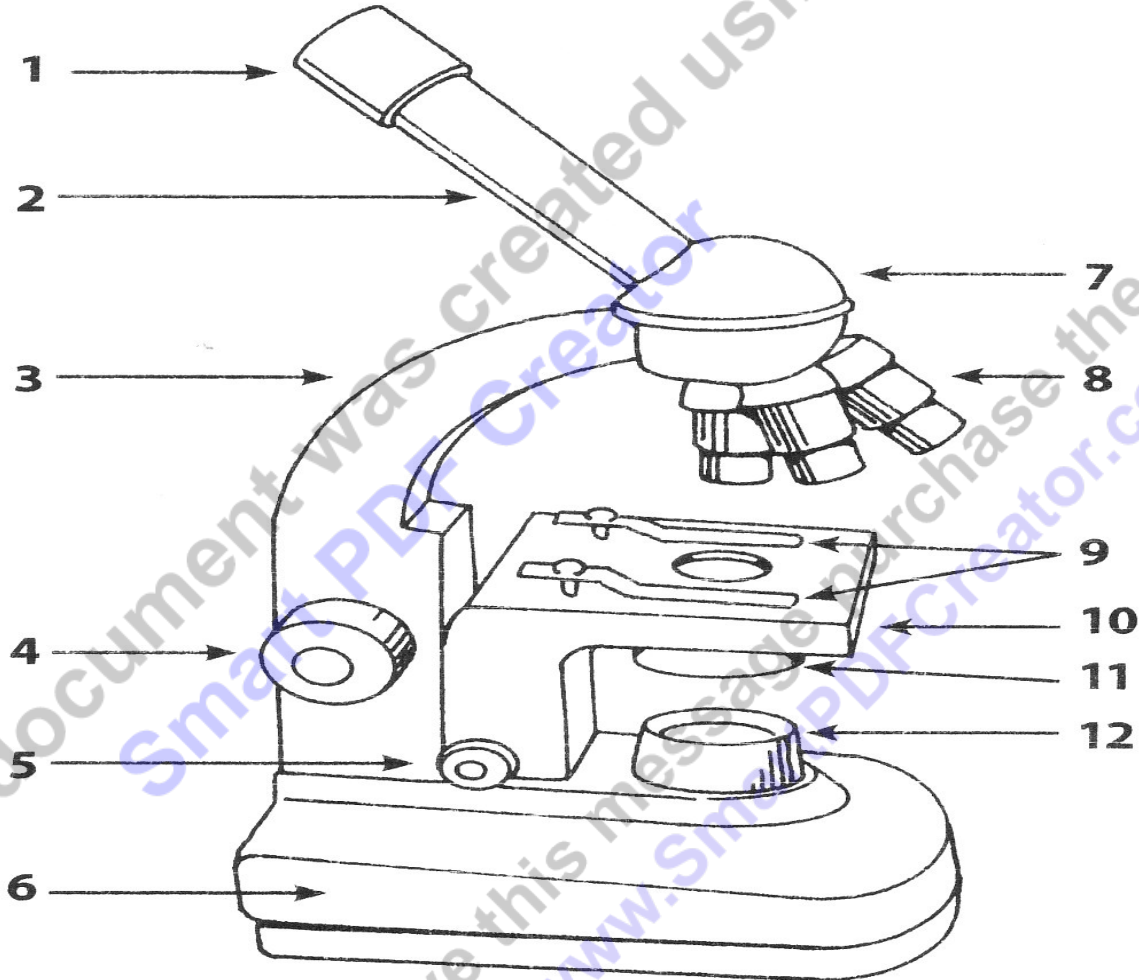

How do you carry a microscope in the lab?

What are three things you should do when putting the microscope away?

3 Part Question! 1.) Please label the high, medium, and low power objective lens. 2) Draw the letter "e" as it appears on low, medium, and high power. 3) Please record the magnification below each circle if you are using a 10x ocular lens in the eyepiece.

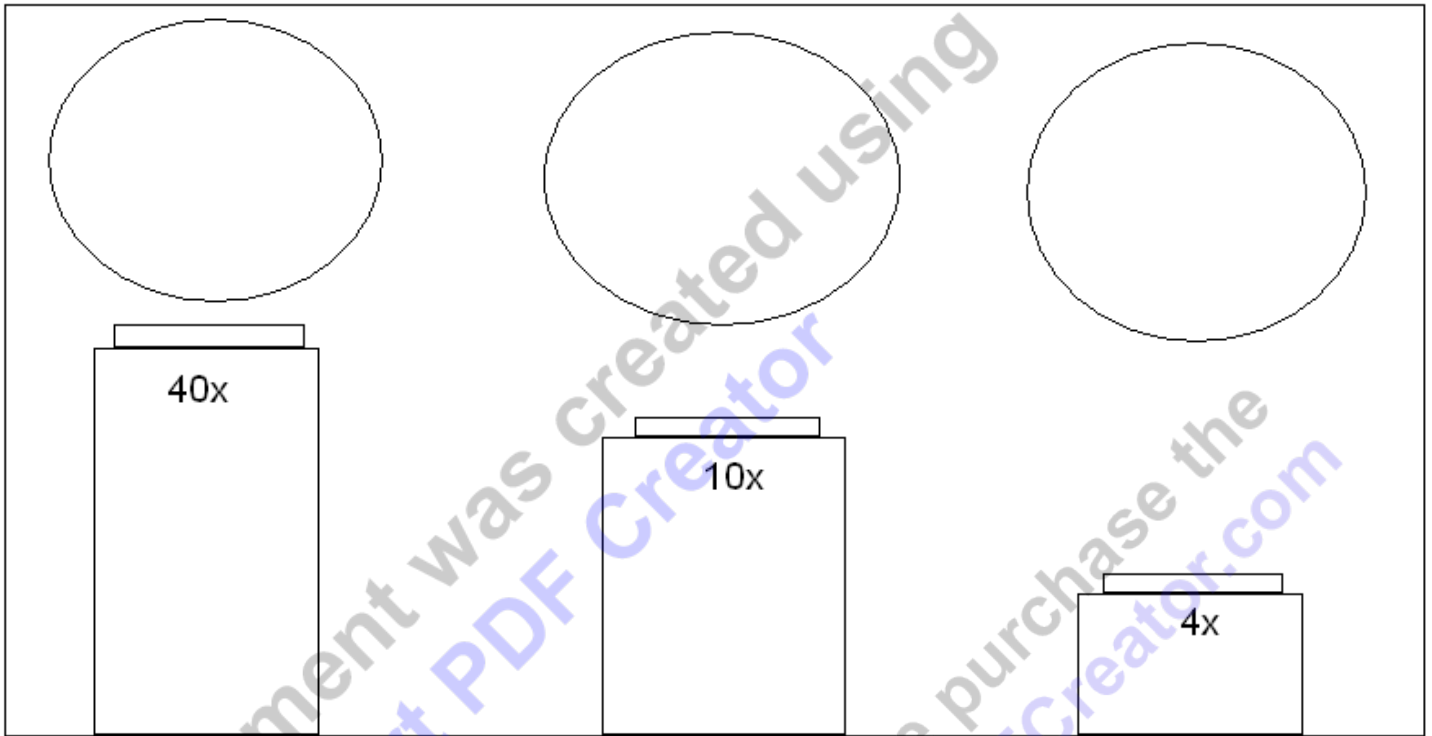

What are the positives and negatives of the "The Old English / American System of measurements?"



What is so important about the number 10 and the metric system? Describe some reasons in the box below. The numbers on the right are there to help you.

Prefix	Symbol	Multiplier	
exa	E	10^{18}	1,000,000,000,000,000,000
peta	P	10^{15}	1,000,000,000,000,000
tera	T	10^{12}	1,000,000,000,000
giga	G	10^9	1,000,000,000
mega	M	10^6	1,000,000
kilo	k	10^3	1,000
hecto	h	10^2	100
deka	da	10^1	10
deci	d	10^{-1}	0.1
centi	c	10^{-2}	0.01
milli	m	10^{-3}	0.001
micro	μ	10^{-6}	0.000,001
nano	n	10^{-9}	0.000,000,001
pico	p	10^{-12}	0.000,000,000,001
femto	f	10^{-15}	0.000,000,000,000,001
atto	a	10^{-18}	0.000,000,000,000,000,001

Use the above chart to assist you if needed to do the SI conversions below.

Convert the following number into the units below.

Kilometers
Hectometers
Decameters
Meters 1
Decimeters
Centimeters
Millimeters
Micrometers

Convert the following number into the units below.

Kilometers
Hectometers
Decameters
Meters
Decimeters
Centimeters
Millimeters 750
Micrometers

Convert the following number into the units below.

Kilometers 5
Hectometers
Decameters
Meters
Decimeters
Centimeters
Millimeters
Micrometers

Please convert the following number into scientific notation. 93,000,000

What is 156,000 in scientific notation?

What is 4.56×10^{-9} ?

Please fill in the missing terms and units in the sequence below.

King	Kilometer	10 ³
_____	Hectometer	100m
Died	_____	10m
While	Standard	10 ⁰
_____	Decimeter	.1m
Chocolate	Centimeter	10 ⁻²
Milk	_____	.001m
_____	_____	10 ⁻³

Please fill in the missing terms and units in the sequence below.

<u>Quantity</u>	<u>Base Unit</u>	<u>Symbol</u>
Length	Meter	_____
_____	Kilogram	_____
Temperature	_____	K
_____	Second	s
Amount	_____	mol
_____	Newton	N
Electric Current	_____	_____
Luminous Intensity	Candela	_____
_____	Liter	l

How long is the line below in...



Meters _____
 Centimeters _____
 Millimeters _____

How long is the rope below in...

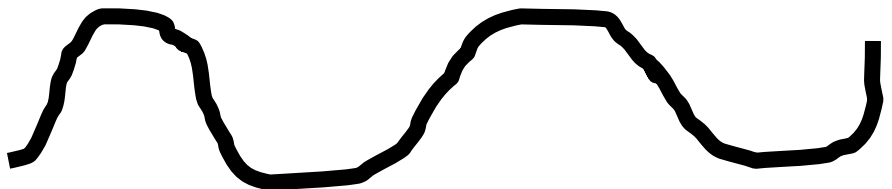

Meters _____
 Centimeters _____
 Millimeters _____

Please add some mass to the equal balance below so that the picture makes sense. Do you know the difference between mass and weight?



What is the volume of the two shapes below?

centimeters

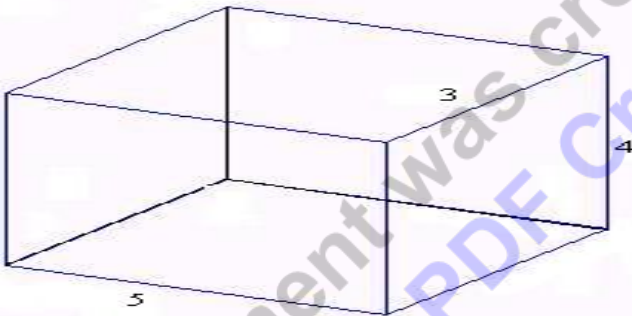

meters



Key:  = 1 cubic meter

Warning! 3 Part Question. 1) What is the volume of the two graduated cylinders? 2) What is the curve of the water called and where should you measure? 3) What is the volume of the toy diver based on water displacement?

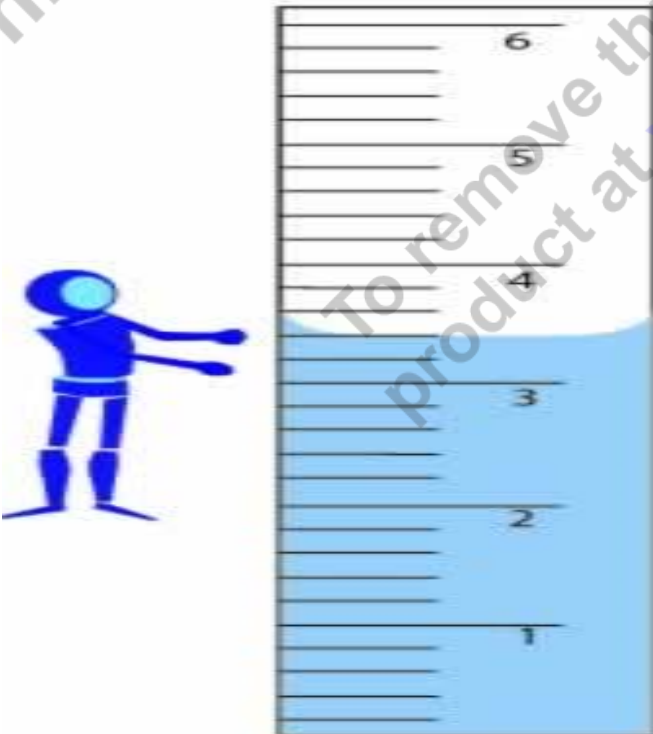

What is the density of an objects whose mass is 500 grams and displaces 250 ml of water?

Density = _____

Will the object float in water? Yes / No

What is the density of an objects whose mass is 200 grams and displaces 250 ml of water?

Density = _____

Will the object float in water? Yes / No

Warning! 3 Part Question. 1) What is the temperature in degrees Celsius? 2) Draw an arrow and label the temperature at which water freezes? 3) At what temperature does water boil?

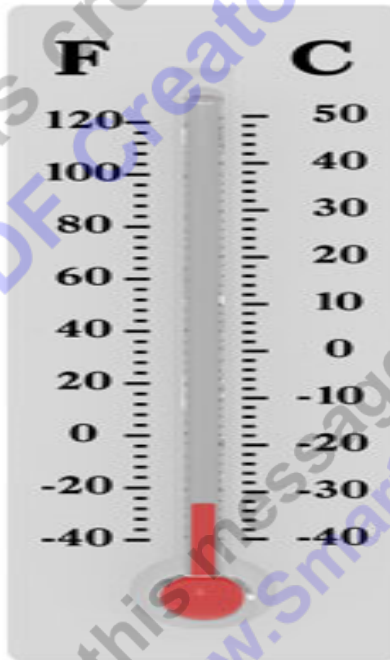

How many...

Seconds in a minute? _____

Minutes in an hour? _____

Seconds in an hour? _____

Hours in a day? _____

Days in a year? _____

Days in a leap year? _____

Seconds in a day? _____

Seconds in a year? _____

Seconds in a decade? _____

(don't forget two leap years)

What are a few other SI units that have not been covered so far on this OFE?

This document was created using
Smart PDF Creator

To remove this message purchase the
product at www.SmartPDFCreator.com